

ICS100

IN-CYLINDER SENSORS

INNOVATION IN MOTION

ICS100 is a range of In-Cylinder linear position sensors designed for integration into hydraulic and pneumatic actuators where the sensor is fitted inside the pressurised environment. Using the proven benefits of Hybrid Track Technology and including a number of unique design features, the ICS100 range is ideally suited to high volume OEM actuator manufacturers, where design engineers can specify an affordable alternative for applications where non-contacting technologies may prove too expensive.

Pneumatic version no longer available

Hybrid track

The hybrid track comprises a high resistivity conductive plastic film bonded to a precision wire-wound element. The conductive plastic film is wiped by a precious metal contact. The technology provides infinite resolution and a very long life (since the majority of the current still flows in the wire, the carbon content of the conductive plastic film is low, and the film is therefore very hard). Track linearity is very good, temperature coefficient of resistance is low and predictable and resistance stability with change in humidity is excellent.



Choice of installation styles

The ICS100 can be supplied with a choice of mounting styles. The Internal flange style (I) is more suited to clevis style actuators, where the pressure flange is hidden within the cylinder bulkhead. The External flange style (EM/EI) is suited to tie-rod style actuators and is fitted through the cylinder rear via a threaded hole.



Features

- Flexible mounting styles
- Absolute analog output
- Cable integrally moulded
- Rapid despatch of any option
 - CE approved
- Competitive price

Benefits

- Suitable for a variety of actuator formats
- No additional electronics required
- Excellent strain relief with secure sealing
- Eliminates customer inventory
- Confidence in EMC performance
- Reduced system cost



EMC Directive 2004/108/EC

The products detailed in this document have been tested to the requirements of EN61000-6-3 (Emissions) and EN61000-6-2 (Immunity).



Quality Assurance

Penny + Giles are accredited to BS EN ISO9001:2008. Quality is at the heart of all our systems ensuring the reliability of our products from initial design to final despatch.

Certificate No.LRQ 0924881

ATEX 94/9/EC (100a) and 1999/92/EC (137) Directives

Penny & Giles ICS100 products are potentiometers and as such are classed as 'simple apparatus' according to the definition in paragraph 3.21 (a) of BS EN60079-14:1997. 'Simple apparatus' is not certified, but may be used as part of an intrinsically safe circuit providing it is used with a suitable interface of associated apparatus (e.g. a safety barrier). A full declaration of compliance can be supplied on request.

ICS100 IN-CYLINDER LINEAR POSITION SENSORS



Removable contact slider assembly

The ICS100 is designed for easy integration into either hydraulic or pneumatic actuators and is supplied with a contact slider ring that can be easily removed from the sensor when installing in the actuator/cylinder rod. The slider ring is color coded for easy identification of the application type - hydraulic (H) option is blue; pneumatic (P) option is black. Mounting hardware is supplied with each sensor to ensure simple, quick installation.

Total reliability

The ICS100 provides a highly reliable solution for absolute position sensing in hydraulic/pneumatic actuators. The self-cleaning, long life contact design and stable, predictable output of the hybrid track improves service life and reduces the need for regular maintenance or re-calibration of the control system.

World leading availability

The ICS100 sensor has been 'designed for manufacture' which enables assembly in a state-of-the-art manufacturing cell. This means that we can supply any one of 125 different lengths, three different flange styles, two different slider ring styles and two cable lengths in three to five days from ordering.

This combination of options equates to 1500 different sensors - all available faster than our competitors.

For that really urgent project, we are flexible enough to be able to despatch the same day as ordered.

Operating fluids - caution

The hydraulic fluid (H) version of the ICS100 has been tested for use in mineral oils only. We do not recommend this sensor for use:-

In systems containing water based fluids (e.g. water glycol)

In systems containing oil with zinc additives present

Where system filtration allows particles greater than 10 microns in size

Information provided in this brochure on product applications should be used by customers for guidance only. Customers should satisfy themselves of the actual performance requirements and subsequently the suitability for any particular design application and the environment in which the ICS100 is to be used.

If you have any doubt about the content, cleanliness or filtration levels of your fluid, we recommend the use of the Penny + Giles contactless in-cylinder transducer range - see our separate brochure on the ICT series.



ICS100 IN-CYLINDER LINEAR POSITION SENSORS

PERFORMANCE

Electrical length E	mm	25 to 200 in 5mm increments 210 to 1100 in 10mm increments (Up to 1600mm can be specified. See options)
Resistance ±10%	kΩ	1 per 25mm length
Independent linearity	±%	0.25 for 25 to 70mm lengths 0.15 for 75 to 1600mm lengths
Power dissipation at 20°C	W	0.5 per 25mm length
Applied voltage - maximum Vdc		22 per 25mm length (maximum 74Vdc)
Resolution		Virtually infinite
Hysteresis (repeatability)		Less than 0.01mm
Operational temperature	°C	-30 to +100
Output smoothness		To MIL-R-39023 grade C 0.1%
Insulation resistance		Greater than 50MΩ at 250Vdc
Operating mode		Voltage divider only - see Circuit Recommendation below
Wiper circuit impedance		Minimum of 100 x track resistance or 0.5MΩ, (whichever is greater)
Slider operating force - max. gf		60
Life		Typically greater than 100 million operations (50 x 10 ⁶ cycles) at 25mm stroke length
Dither life		200 million operations (100 x 10 ⁶ cycles) at ±0.5mm 60Hz
Slider velocity - maximum	m/s	10 in pneumatic applications 4 in hydraulic applications (ISO VG 32 mineral oil)
Vibration		RTCA/DO-160D 10Hz to 2000Hz, 4.12g (rms) - all axes
Shock		40g, 6.0mS, half sine profile - all axes
Pressure - working	Bar	500 maximum
burst	Bar	> 700
pulsed	Bar	0 to 500 in 1 second (tested to 25,000 cycles)
Working fluid		Tested for mineral oils only. Not recommended for water based fluids or systems containing zinc additives. See cautionary note on page 3.

OPTIONS

Electrical length	Length from 1110mm up to 1600mm can also be supplied in 10mm increments. Please discuss your application with our sales team before ordering.
Mounting	Internal or external flange styles can be specified
Cylinder environment	Hydraulic (H)
Extended cable length	1m or 10m output cable can be specified

AVAILABILITY

All standard configurations can be supplied rapidly from the factory - check with your local supplier for more details

ORDERING CODES

		ICS100/...../...../...../.....	
Internal flange	=	IN	
External flange metric	=	EM	
- imperial	=	EI	
Electrical length mm (see page 6 on how to calculate)			

Pneumatic version no longer available

INSTALLATION

An installation kit is provided comprising: O rings, wave washers, shims and circlips. Full details on recommendations for cylinder designers are shown on pages 6 & 7

CIRCUIT RECOMMENDATION

Hybrid track potentiometers feature a high wiper contact resistance, therefore operational checks should be carried out only in the voltage divider mode. Hybrid track potentiometers should be used only as voltage dividers, with a minimum wiper circuit impedance of 100 x track resistance or 0.5MΩ (whichever is greater). Operation with wiper circuits of lower impedance will degrade the output smoothness and affect the linearity.

DIMENSIONS

INTERNAL FLANGE

ICS100/IN

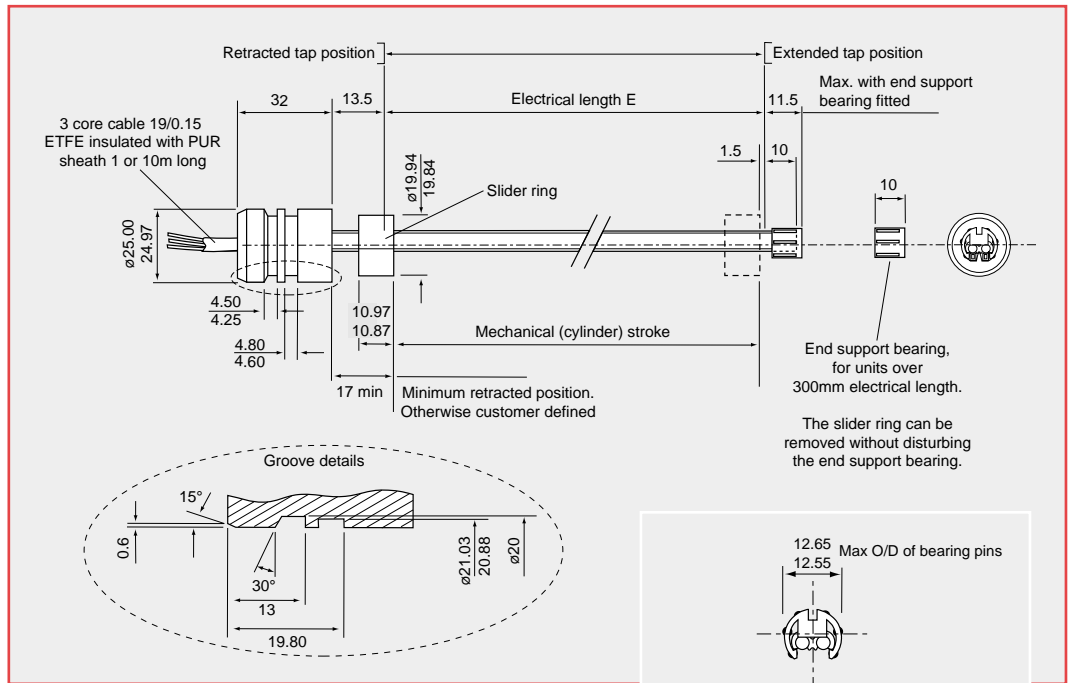

View with end support bearing fitted (flange and slider ring omitted for clarity)

EXTERNAL FLANGE

ICS100/EI or EM

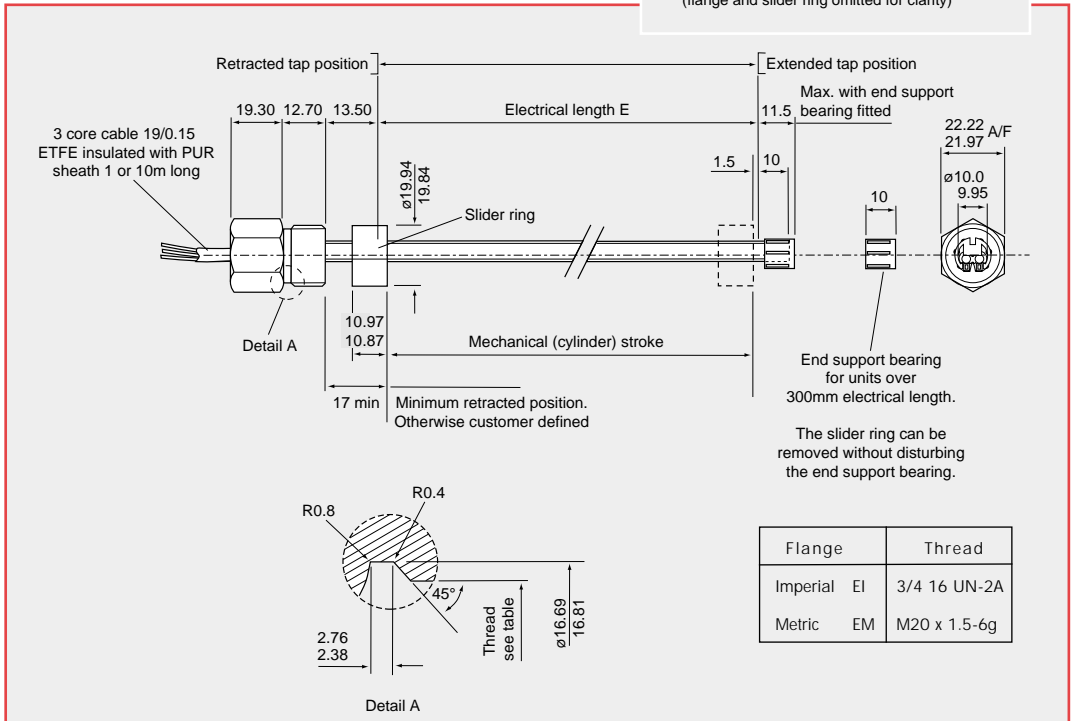

ELECTRICAL CONNECTIONS

3 core cable: PUR sheathed
1m or 10m long with ETFE
insulated 19/0.15 cores

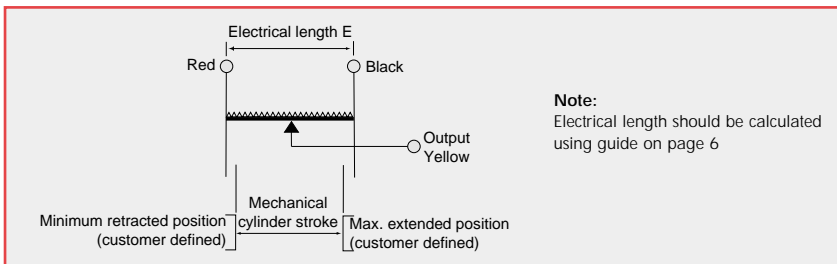

ICS100 DESIGNERS GUIDE FOR ORDERING AND INSTALLATION

The ICS100 sensor is designed for use inside hydraulic or pneumatic actuators and to ensure the correct calculation of the electrical length for ordering purposes, these notes have been developed to assist cylinder designers determine the key dimensions. If you encounter any difficulty with these instructions, please use the contact details on the rear cover to ask for assistance.

In most applications, the designer will need answers to the following questions:

- What length of sensor do I need to order to match my cylinder stroke? - see STEP 1
- How deep should I bore the cylinder rod? - see STEP 2
- What is the machining detail for the sensor attachment? - see STEP 3

STEP 1 - Calculate electrical length - E This is part of the ordering code

The sensor can only be ordered by **electrical length** - not mechanical stroke of the actuator / cylinder. (Refer to fig.1 and 2)

The formula to use is $E = a + b - 1.03\text{mm}$

Where

- a** = Maximum mechanical stroke of actuator/cylinder in mm*
- b** = user defined dead length*

-1.03mm constant = $c_1 + c_2 - c_3$ (including maximum tolerances)

Select a sensor from the range that has a value for **E** equal to or greater than the calculated length. Note that the ICS100 can be ordered in increments of 5mm for 25mm to 200mm lengths, and increments of 10mm for 210mm to 1600mm lengths.

Typical working example:

Cylinder mechanical stroke a	= 321.0 ±1.0mm
User defined dead length b	= 6.70 ±0.5mm
Constant	= -1.03mm
Sensor	= External flange, metric thread; hydraulic use; 1m cable

Maximum electrical length (including positive tolerances) = $322 + 7.2 - 1.03 = 328.17\text{mm}$

From the available range, the next closest length to 328.17mm is **330mm**, so select this in the ordering code. Full ordering code for this selection would be: **ICS100/EM/0330/H/01**

Calculating the sensor body length

For reference, the maximum sensor body length (see dimension **d** on figs.1 & 2) can be calculated using the following formula once **E** has been determined. Use datum **X** of the sensor pressure flange.

- i) For sensors below 300mm electrical length (without the end support bearing fitted) $d = E + 24.0\text{mm}$
(24.0mm constant is calculated* as $c_3 + g = [13.5 + 0.25] + [10.0 + 0.25]$)

*Including maximum tolerances

- ii) For sensors 300mm electrical length and above (with the end support bearing fitted) $d = E + 25.5\text{mm}$
(25.5mm constant is calculated* as $c_3 + h = [13.5 + 0.25] + [11.5 + 0.25]$)

Working example for ICS100/EM/0330/H/01

This sensor with a 330mm electrical length will be supplied with an end support bearing, so use calculation ii) Maximum sensor body length **d** (including positive tolerances) = $330 + 25.5 = 355.5\text{mm}$

STEP 2 - Calculate full diameter drill depth of cylinder rod

Calculate the full diameter drill depth from counter bore spot face (see dimension **f** on figs. 1 & 2)

The following calculation assumes that the cylinder rod is in the fully retracted position against a mechanical stop and that the slider ring is fully located against the spot face of the slider ring location bore. This position is shown as datum **Y** in figs. 1 and 2.

- iii) For sensors below 300mm electrical length (without the end support bearing fitted) $f = E - b + 18.03$
(18.03mm constant is calculated as $c_3 - c_2 + g + 5\text{mm [clearance]} = [13.5 + 0.25] - [10.97] + [10.0 + 0.25] + 5$)

Suggested cylinder rod bore diameter is 11.0mm minimum.

- iv) For sensors 300mm electrical length and above (with the end support bearing fitted) $f = E - b + 19.53$
(end support bearing adds 1.5mm to sensor length)
Suggested cylinder rod bore diameter is 13.0mm minimum.

Working example for ICS100/EM/0330/H/01

This sensor with a 330mm electrical length will be supplied with an end support bearing, so use calculation iv)
 $f = E - b + 19.53 = 330 - 6.2 + 19.53 = 343.33\text{mm}$

In this working example, we suggest the full diameter bore depth from datum **Y** is 344mm (rounded up to the nearest mm)

In these calculations, we have suggested a 5mm clearance to eliminate any chance of the sensor hitting the limit of the cylinder rod bore at the fully retracted position.

STEP 3 - Machine cylinder rod and rear bulkhead

Using the detail from fig.3, machine the cylinder rod to accept the slider ring (same for both styles whether H hydraulic or P - pneumatic). Ensure the slider ring is fitted correctly - as notes on fig.3

Use the detail in fig.1 or fig.2 (depending on flange style) to machine the rear bulkhead to accept the sensor.

Each sensor is supplied with the mounting hardware to mount the sensor and slider ring assembly. The generic kit includes all components for all types of sensor available. Spare mounting hardware kits can be ordered as part number AI200535

Fig 1 INTERNAL FLANGE ICS100/IN

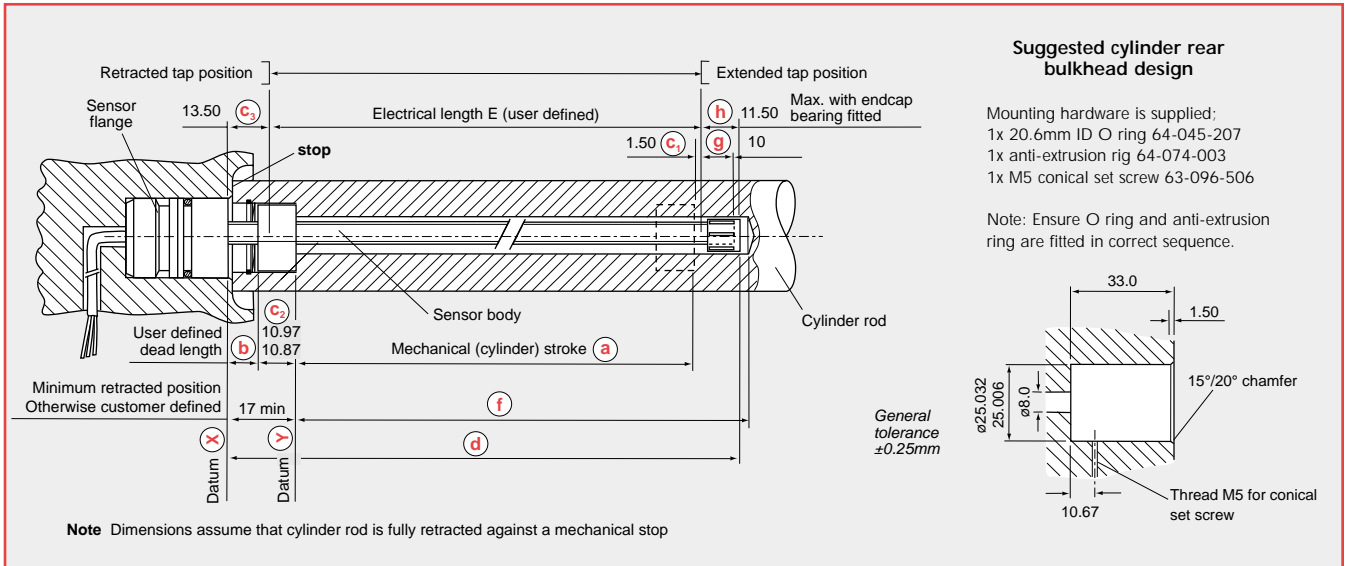

Fig 2 EXTERNAL FLANGE ICS100/EI & EM

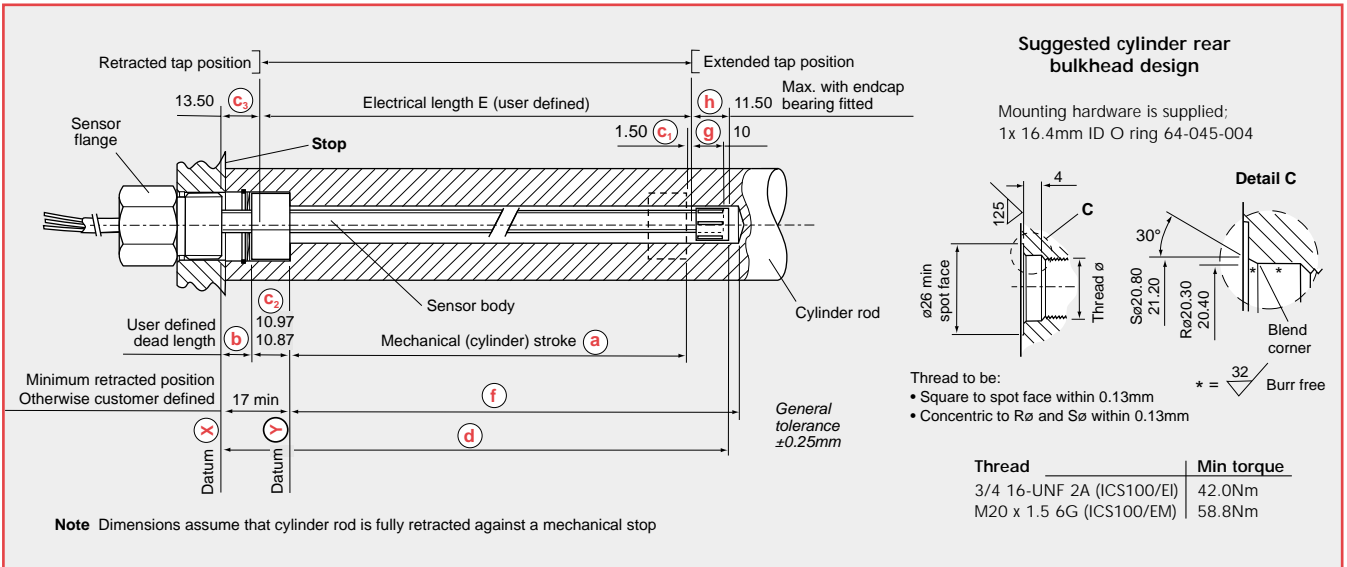
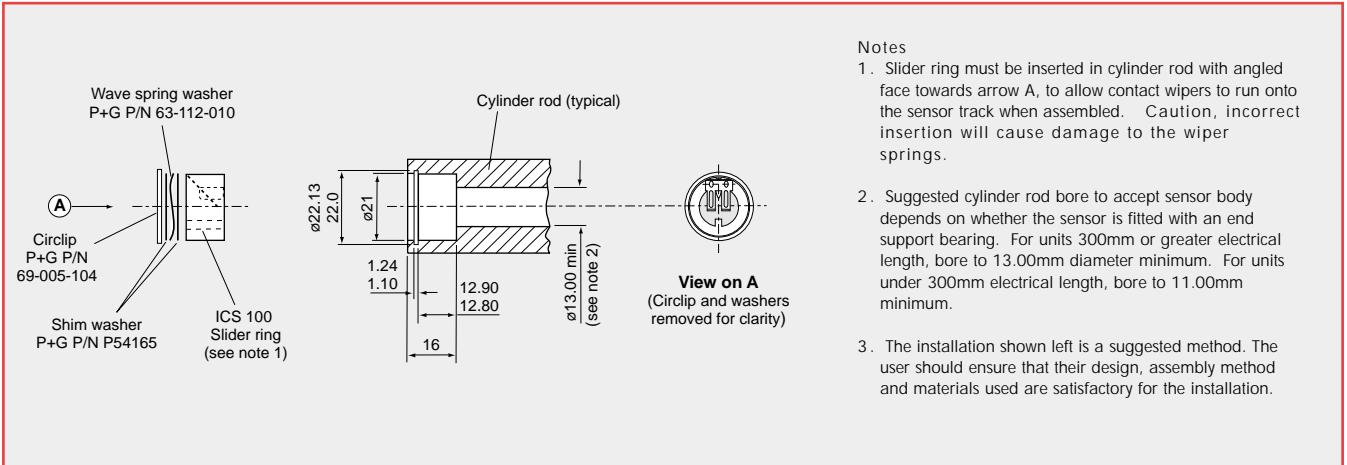

Fig 3 SLIDER RING ICS100 - mounting instructions and dimensions for boring cylinder rod.





www.pennyandgiles.com

Penny & Giles

Position sensors, joysticks and solenoids for commercial and industrial applications.

15 Airfield Road
Christchurch
Dorset BH23 3TG
United Kingdom
+44 (0) 1202 409499
+44 (0) 1202 409475 Fax
sales@pennyandgiles.com

36 Nine Mile Point Industrial Estate
Cwmfelinfach
Gwent NP11 7HZ
United Kingdom
+44 (0) 1495 202000
+44 (0) 1495 202006 Fax
sales@pennyandgiles.com

665 North Baldwin Park Boulevard
City of Industry, CA 91746
USA
+1 626 480 2150
+1 626 369 6318 Fax
us.sales@pennyandgiles.com

Straussenlettenstr. 7b
85053 Ingolstadt,
Germany
+49 (0) 841 885567-0
+49 (0) 841 885567-67 Fax
info@penny-giles.de

3-1-A, Xiandai Square,
No 333 Xingpu Rd,
Suzhou Industrial Park, 215126
China
+86 512 6287 3380
+86 512 6287 3390 Fax
sales@pennyandgiles.com.cn

The information contained in this brochure on product applications should be used by customers for guidance only. Penny+Giles Controls Ltd makes no warranty or representation in respect of product fitness or suitability for any particular design application, environment, or otherwise, except as may subsequently be agreed in a contract for the sale and purchase of products. Customer's should therefore satisfy themselves of the actual performance requirements and subsequently the products suitability for any particular design application and the environment in which the product is to be used.

Continual research and development may require change to products and specification without prior notification. All trademarks acknowledged.

© Penny+Giles Controls Ltd 2012

Innovation In Motion



www.cwcontrols.com